

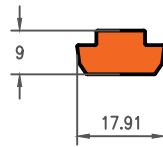

Darshan Extrusions Pvt. Ltd.

Die No.19056

0.352Kg/m



Die No.19169

0.429Kg/m

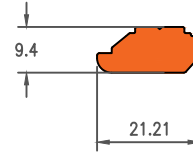

Die No.19057

0.392Kg/m

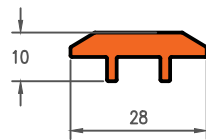

Die No.19181

0.661Kg/m

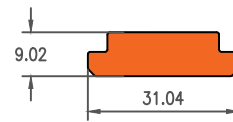

Die No.19131

0.389Kg/m

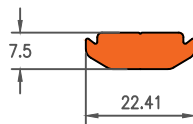

Die No.19006

0.389Kg/m

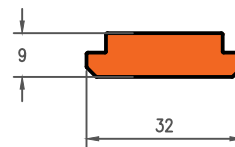

Die No.19159

0.203Kg/m

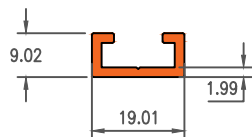

Die No.19163

0.205Kg/m

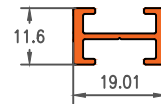

SOLAR



Darshan Extrusions Pvt. Ltd.

Die No.19069

0.809Kg/m

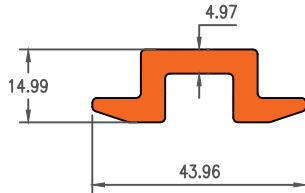

Die No.19432

0.750Kg/m

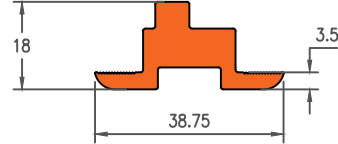

Die No.19811

0.277Kg/m

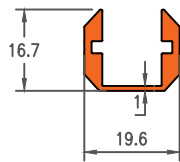

Die No.19831

0.247Kg/m

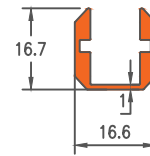

Die No. 19130

0.260Kg/m

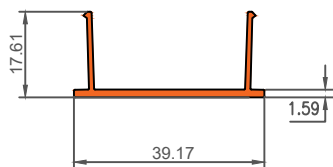

Die No.10203

0.358Kg/m

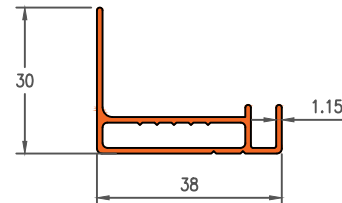

Die No.7001

0.786Kg/m

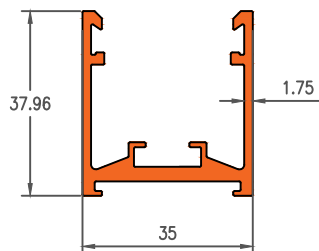

Die No.19051

0.695Kg/m

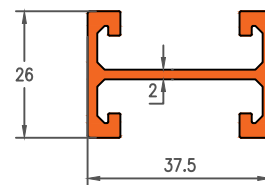

SOLAR



Darshan Extrusions Pvt. Ltd.

Die No.7002

0.647Kg/m

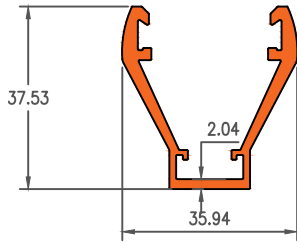

Die No.7003

0.590Kg/m

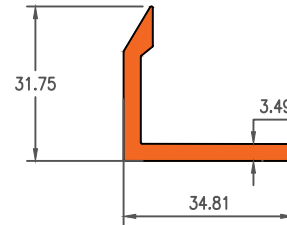

Die No.19135

0.551Kg/m

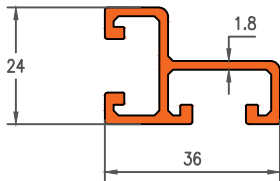

Die No.19162

0.909Kg/m

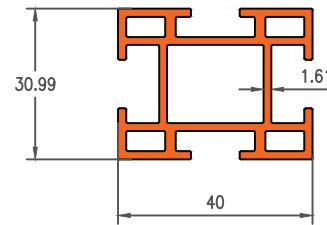

Die No.7006

0.495Kg/m

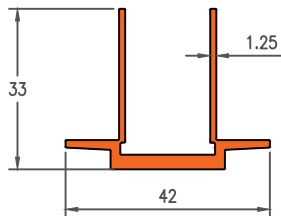

Die No.7037

0.822Kg/m

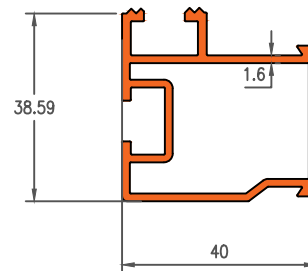

Die No.7047

0.189Kg/m

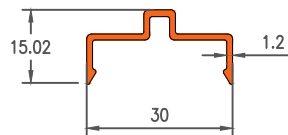

Die No.7048

0.632Kg/m

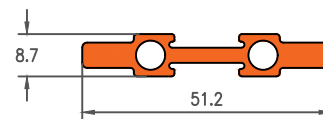

SOLAR



Darshan Extrusions Pvt. Ltd.

Die No.7049

0.222Kg/m

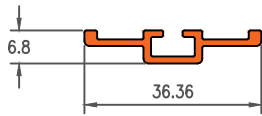

Die No.19054

0.921Kg/m

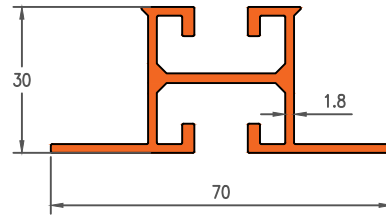

Die No.7004

0.757Kg/m

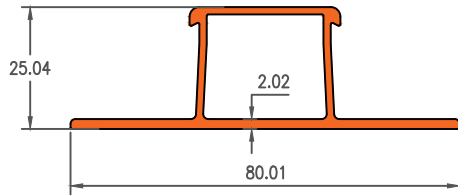

Die No.19196

0.972Kg/m

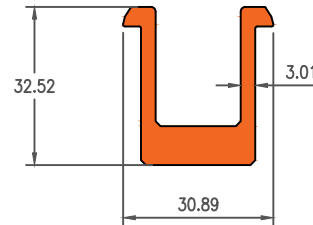

Die No.19039

0.617Kg/m

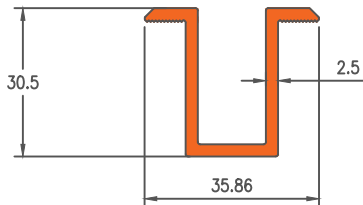

Die No.19005

0.681Kg/m

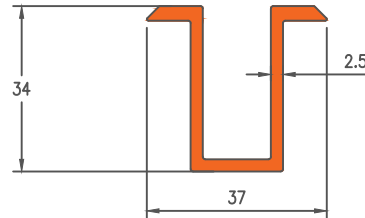

Die No.19374

2.876Kg/m

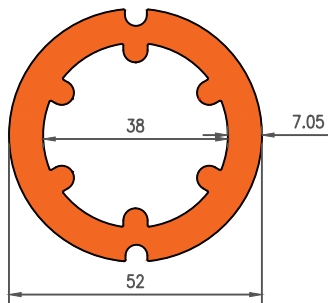

Die No.19133

0.749Kg/m

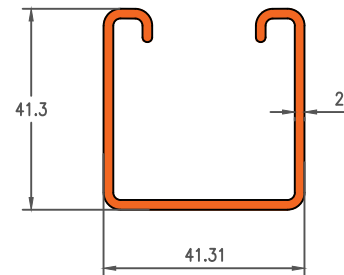

SOLAR



Darshan Extrusions Pvt. Ltd.

Die No.19040

0.534Kg/m

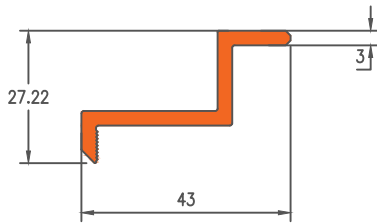

Die No.19043

0.565Kg/m

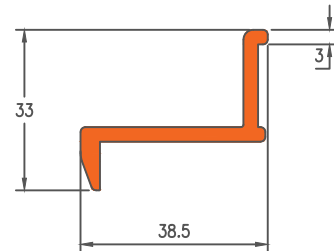

Die No.19044

0.606Kg/m

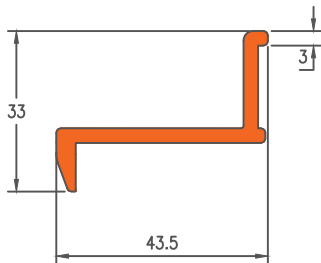

Die No.19055

0.529Kg/m

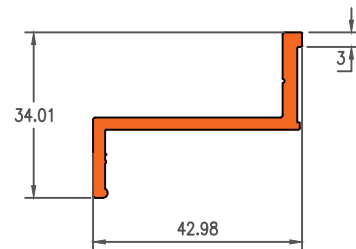

Die No.20055

0.656Kg/m

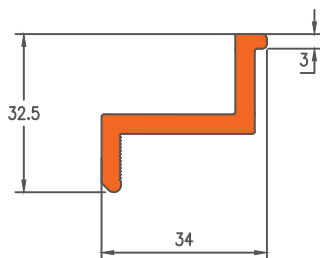

Die No.19070

0.403Kg/m

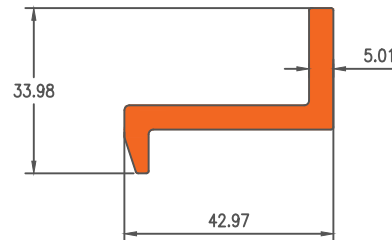

Die No.19004

0.576Kg/m

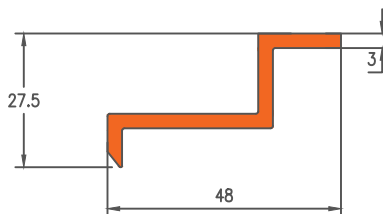

SOLAR



Darshan Extrusions Pvt. Ltd.

Die No.7028

1.176Kg/m

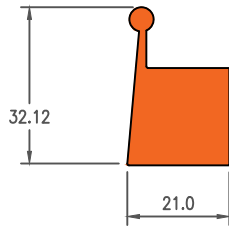

Die No.7027

2.489Kg/m

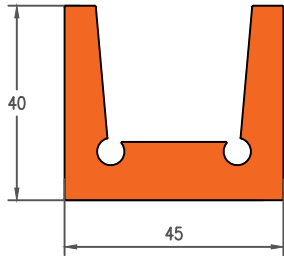

Die No.7026

0.269Kg/m

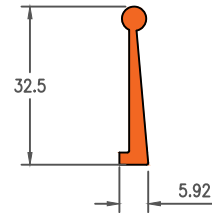

Die No.19042

3.465Kg/m

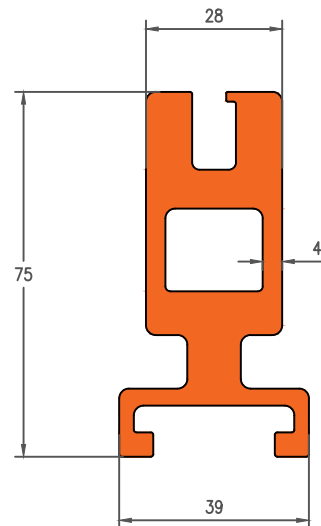

SOLAR



Darshan Extrusions Pvt. Ltd.

Die No.19041

4.561Kg/m

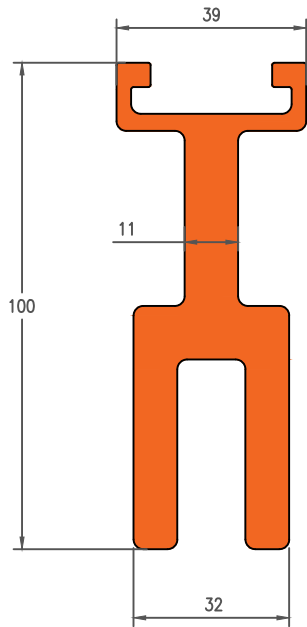

Die No.19488

3.022Kg/m

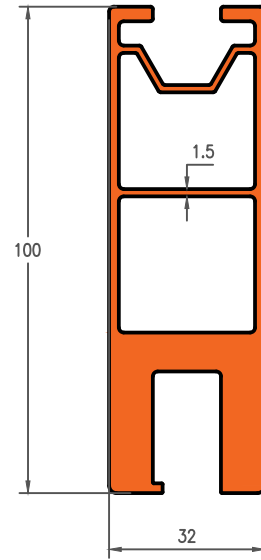

Die No.19097

1.458Kg/m

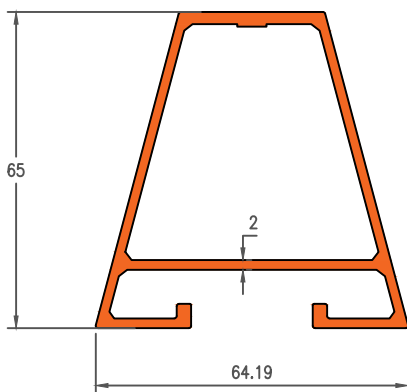

Die No.16104

1.593Kg/m

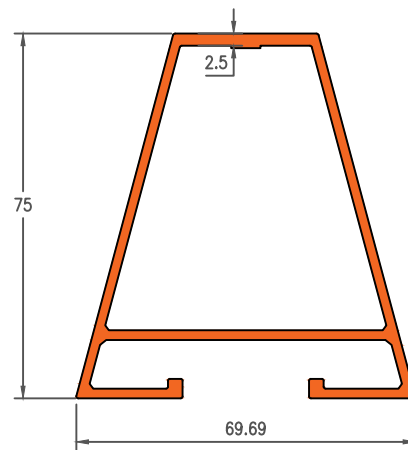

SOLAR



Darshan Extrusions Pvt. Ltd.

Die No.19007

1.218Kg/m

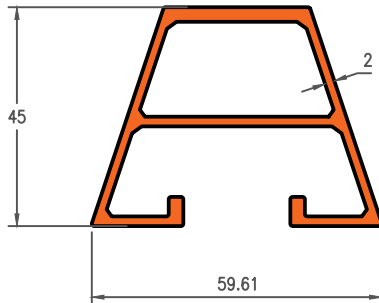

Die No.19087

1.030Kg/m

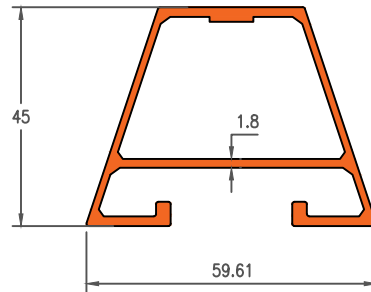

Die No.16217

1.298Kg/m

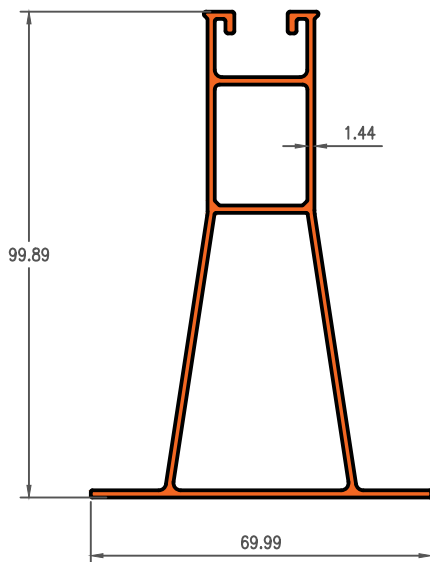

Die No.19433

1.669Kg/m

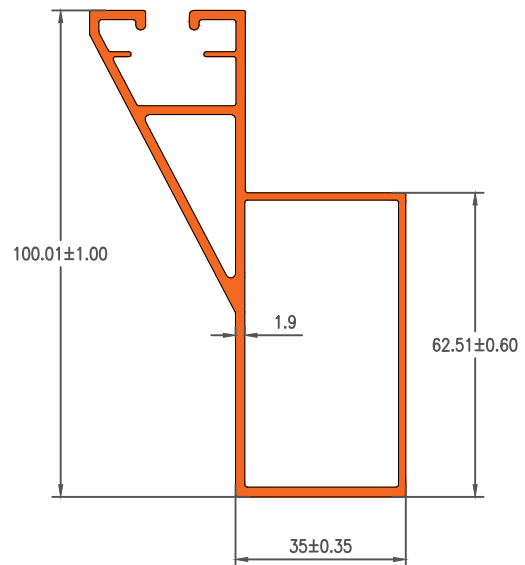

Die No.19999

1.254Kg/m

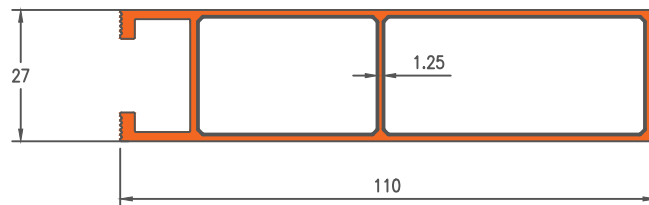

SOLAR



Darshan Extrusions Pvt. Ltd.

Die No.19165

1.217Kg/m

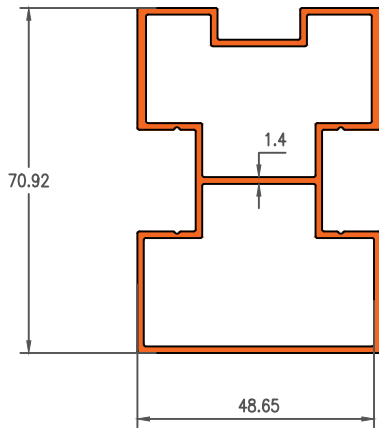

Die No.19160

1.286Kg/m

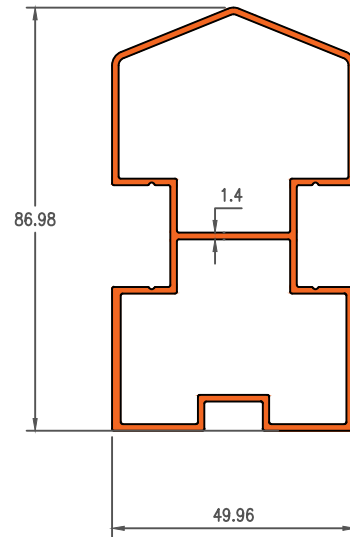

Die No.19079

1.056Kg/m

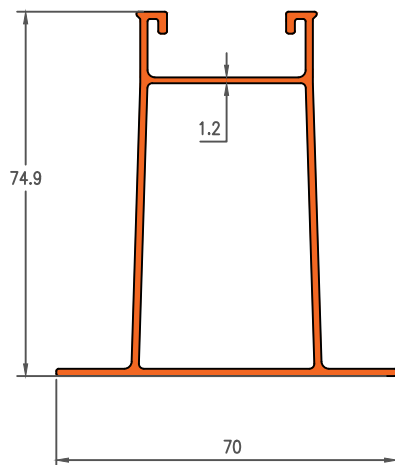

Die No.21020

1.309Kg/m

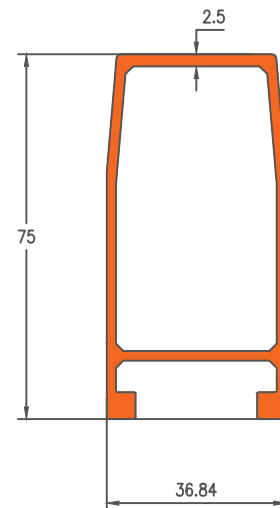

SOLAR